

F gasket and flange tank using five screws with electric hand driller (Figure 3)

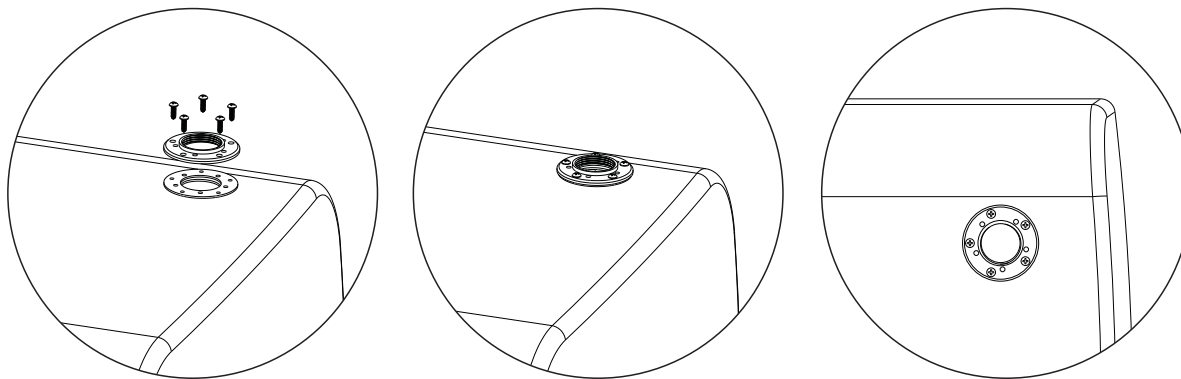

Figure. 3

www.kus D.com

KUS

Since 1984

