

KMG-30T Instruction Manual



CONTENTS

- I、 Gauge and Accessories in Package01
- II、 Installation Steps01
- III、 Appearance Parameter03
- IV、 Electronic Parameter03
- V、 PINS Definition03
- VI、 KMG-30T Usage04
- VII、 Modify system Settings05
- VIII、 Menu Diagram Setting06
- IX、 NMEA2000 & J1939 Parameter Group Number (PGN)07

www.kusauto.com

KMG-30T is a multi-functional round LCD instrument, which can display multi-kinds of data at the same time: RPM, speed, fuel level, water temperature, oil pressure, hour meter, and it supports NMEA 2000, J1939, and analog signal input.

I、 Gauge and Accessories in Package

KMG-30T instrument, CAN-BUS cable, Analog signal cable, GPS antenna and Instruction manual.

II、 Installation Steps

1. Drill a 97.5mm (3 27/32") hole on the panel (II) and make sure a clearance of 80mm (3 1/4") on the backside of the panel exists for KMG-30T gauge.
2. Remove fastening ring (I), insert KMG-30T gauge from front side, and use the fastening ring (I) to fix the gauge (III) after position adjustment.
3. Connect wires and GPS cable to meter (IV).
4. Connect the cable to the connector hole on the backside of KMG, the other end connects with NMEA2000 network. If you chose analog signal input, the pin of analog signal input needs to be connected with sensor.

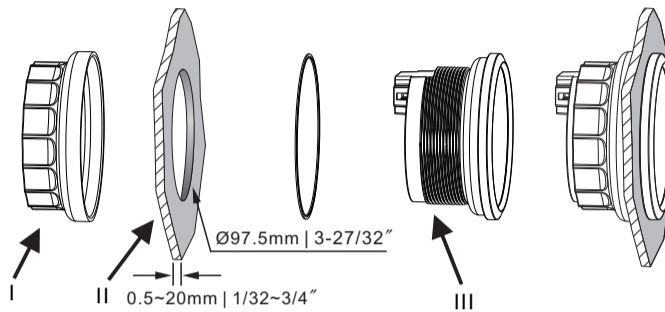

01

www.kusauto.com

GPS Antenna Installation:

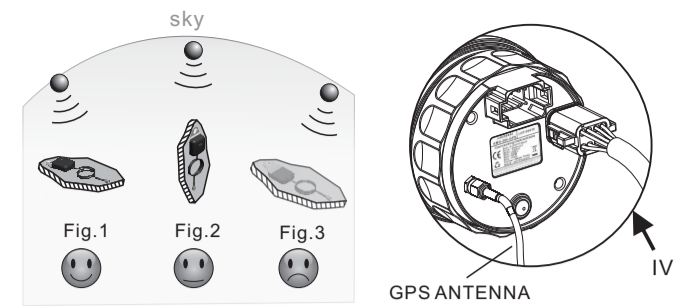

5. Install the GPS antenna outdoors and ensure that GPS antenna receiving signals faces the sky, as shown in Fig.1; If the GPS antenna is installed as shown in Fig.2, the reception of GPS signal will be impacted; If the GPS antenna is installed as shown in Fig.3, it will have a negative impact on the GPS signal and it will not be received.
6. It takes about one minute for the instrument to receive the satellite signal when powered on. Normally when the signal is strong, the location can be completed within 40 seconds (the initial positioning may take 1-2 minutes). Once the boat moves, and the pointer will move and show relative speed over ground (SOG). All the data will not change when the boat stops, so the pointer cannot be used for reference. All data will become accurate once the boat moves.

www.kusauto.com

02

III、 Appearance Parameter

1. Dimension : 3.0 inch
2. Resolution : 432*432 pixels
3. Mounting Dimension : φ97.5 mm
4. Appearance Dimension : φ102,5 mm

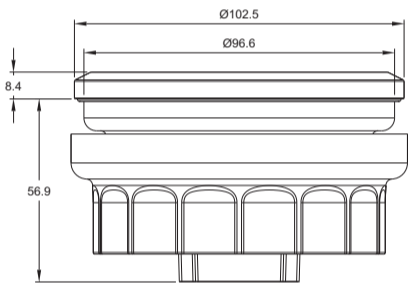

IV、 Electronic Parameter

1. Working voltage : 9 – 32 VDC
2. Working current : ≤170mA (12V)
3. Working temp. : -30~+85 °C(-22°F~+185°F)
4. Storage temp. : -30~+85 °C(-22°F~+185°F)

V、 PINS Definition

1. 4 cores cable red wire-RPM
2. 4 cores cable blue wire-Fuel Level
3. 4 cores cable yellow wire-Water Temp.
4. 4 cores cable black wire-Oil Pressure
5. 2 cores cable red wire-Battery(+)
6. 2 cores cable black wire-Battery(-)
7. CAN-H
8. CAN-L

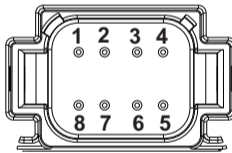

03

www.kusauto.com

VI、 KMG-30T Usage

1. All operations of KMG-30T are completed by touch screen.
2. Click " " at the bottom of the screen on the home page then enter the Settings page.
3. When locked, you need to enter the correct password to reach the Settings page. The password length is four digits and the default initial password is 1234.
4. Locking function is optional. See section 7 for details.

*Note: when using analog signal input, please pay attention to the insulation at the end of the unused analog signal cables. It is strictly forbidden for the power cord and signal line to touch together.

04

VII、 Modify system Settings

1. Modify Display Style : Setting → Display Setting → Style Setting
2. Modify Locking Password: Setting → Lock Setting → Reset Password
3. Modify Locking Time: Setting → Lock Setting → Lock Time
4. Modify GPS Speed Units : Setting → Display Setting → GPS Setting → Unit Setting
5. Modify the GPS Signal Source : Setting → Display Setting → GPS Setting → Signal Setting
6. Modify Fuel Level, Water Temp., Oil Pressure Alarm Value : Setting → Alarm Setting
7. Modify Signal Input : Setting → Input Select
8. Modify Signal Settings : Setting → Input Setting

www.kusauto.com

05

VIII、 Menu Diagram Setting

Setting	Display Setting	Style Setting		Style 1/Style 2	
		GPS Setting		GPS Antenna	
		NMEA2000 Network			
		Unit Setting	Speed Unit	knots/(km/h)/MPH	
			Temp. Unit	Celsius/Fahrenheit	
			Pressure Unit	Bar/PSI	
		Brightness		10%~100%	
	Color Setting		White/Black		
	Alarm Setting	Fuel Level	0~100%		
		Water Temp	40~120°C/100~250°F		
		Oil Pressure	0~10bar/0~145psi		
		Voltage	8-12v		
	Input Select	NMEA 2000			
		J1939			
		ANALOG			
Instance		Engine Instance	0-15		
		Fuel Instance	0-15		
Fuel Level		0-190 ohm			
		240-33 ohm			
		Customized			
Water Temp.		301-23 ohm			
		Customized			
Oil Pressure	10-185 ohm				
	Customized				
Ratio Setting	0.5-250				
Lock Setting	Reset Password				
	Lock Time				
	Lock ON/OFF				

IX、 NMEA2000 & J1939 Parameter Group Number (PGN)

NMEA2000

PGN	PGN name	DD#	Field Name
127488	Engine Parameters	129	Engine Speed
127505	Fluid Level	208/215	Fluid Type/Fluid Level
127489	Engine Parameters	049	Engine oil pressure
		043	Engine temp.
127508	Battery Status	132	Total engine hours
		136	Battery Voltage

SAE-J1939

PGN	PGN name	SPN	Parameter Name
61444	Electronic Engine Controller 1	190	Engine Speed
65276	Dash Display	96	Fuel Level
65263	Engine Fluid Level/Pressure 1	100	Engine Oil Pressure
65262	Engine Temperature 1	110	Engine Coolant Temperature
65253	Engine Hours	247	Engine Total Hours of Operation
65271	Vehicle Electrical Power 1	158	Keys witch Battery Potential

*When the gauge is not in use, please put on the matched cover to protect the gauge.

KUS

Since 1984
www.kusauto.com



06

www.kusauto.com

07

www.kusauto.com